



# **Creative Fabrica**

**Embroidery Design  
Sewing Information**

**[www.creativefabrica.com/embroidery/](http://www.creativefabrica.com/embroidery/)**

© Creative Fabrica

# Production Worksheet

Wilcom EmbroideryStudio - Designing

**\*06\***



Design: **06**

Title:

Stitches: 7,355  
 Height: 4.00 in  
 Width: 5.12 in  
 Colors: 2  
 Colorway: Colorway 1  
 Zoom: 1:1

Machine format: Tajima  
 Color changes: 1  
 Stops: 2  
 Trims: 7  
 Appliqués: 0  
 Left: 56.9 mm  
 Right: 73.1 mm  
 Up: 95.0 mm  
 Down: 6.7 mm  
 EndX: 2.40 in  
 EndY: 3.12 in  
 Area: 20.50 in<sup>2</sup>  
 Max stitch: 6.9 mm  
 Min stitch: 0.2 mm  
 Max jump: 6.5 mm  
 Total thread: 138.85ft  
 Total bobbin: 53.29ft

Stop Sequence:

#	N#	Color	St.	Code	Name	Chart
1.	1		6,287	R242 G225 B110		
2.	3		1,066	R204 G204 B204		

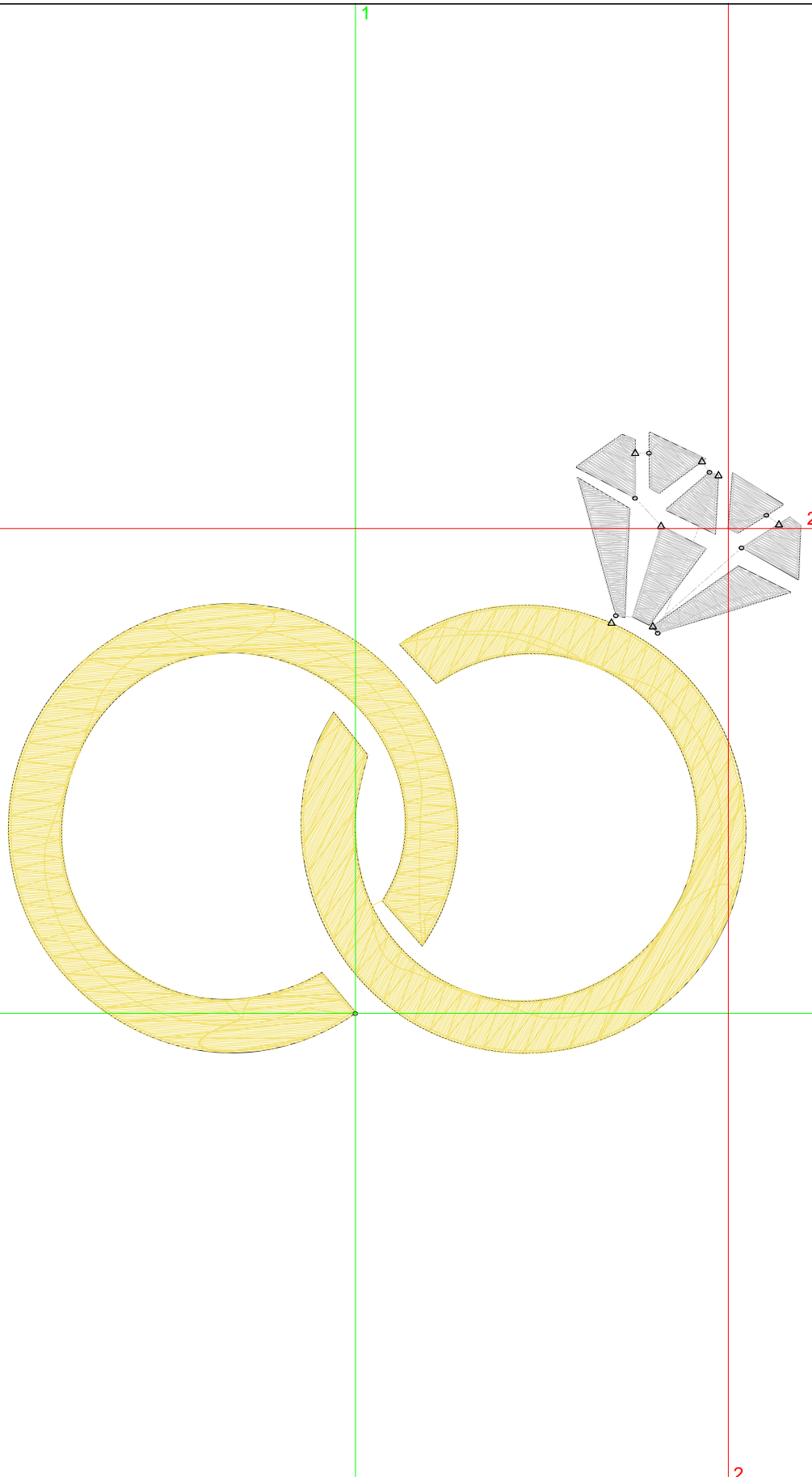

# Color Film

Wilcom EmbroideryStudio - Designing

\*06\*

Design: 06

Title:

Stitches: 7,355  
Height: 4.00 in  
Width: 5.12 in  
Colors: 2  
Colorway: Colorway 1  
Zoom: 0.36

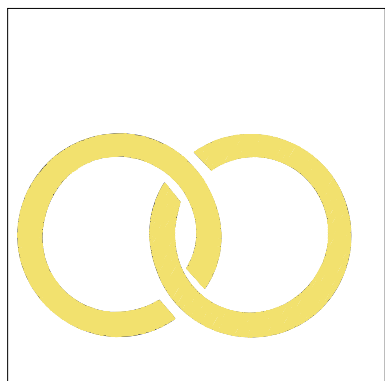

Stop #: 1  
Element:  
Code:  
Name: R242 G225 B110  
Chart:  
Stitches: 6,287  
Thread used: 114.88ft

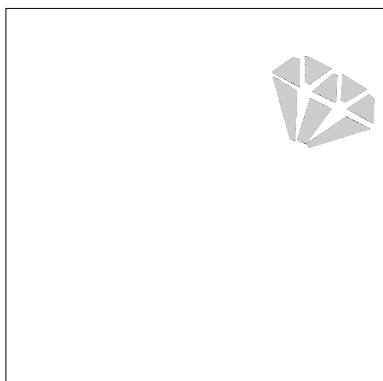

Stop #: 2  
Element:  
Code:  
Name: R204 G204 B204  
Chart:  
Stitches: 1,066  
Thread used: 23.30ft

# Production Worksheet

Wilcom EmbroideryStudio - Designing

\*06\*

Design: 06

Title:

Stitches: 10,442  
Height: 5.00 in  
Width: 6.40 in  
Colors: 2  
Colorway: Colorway 1  
Zoom: 1:1

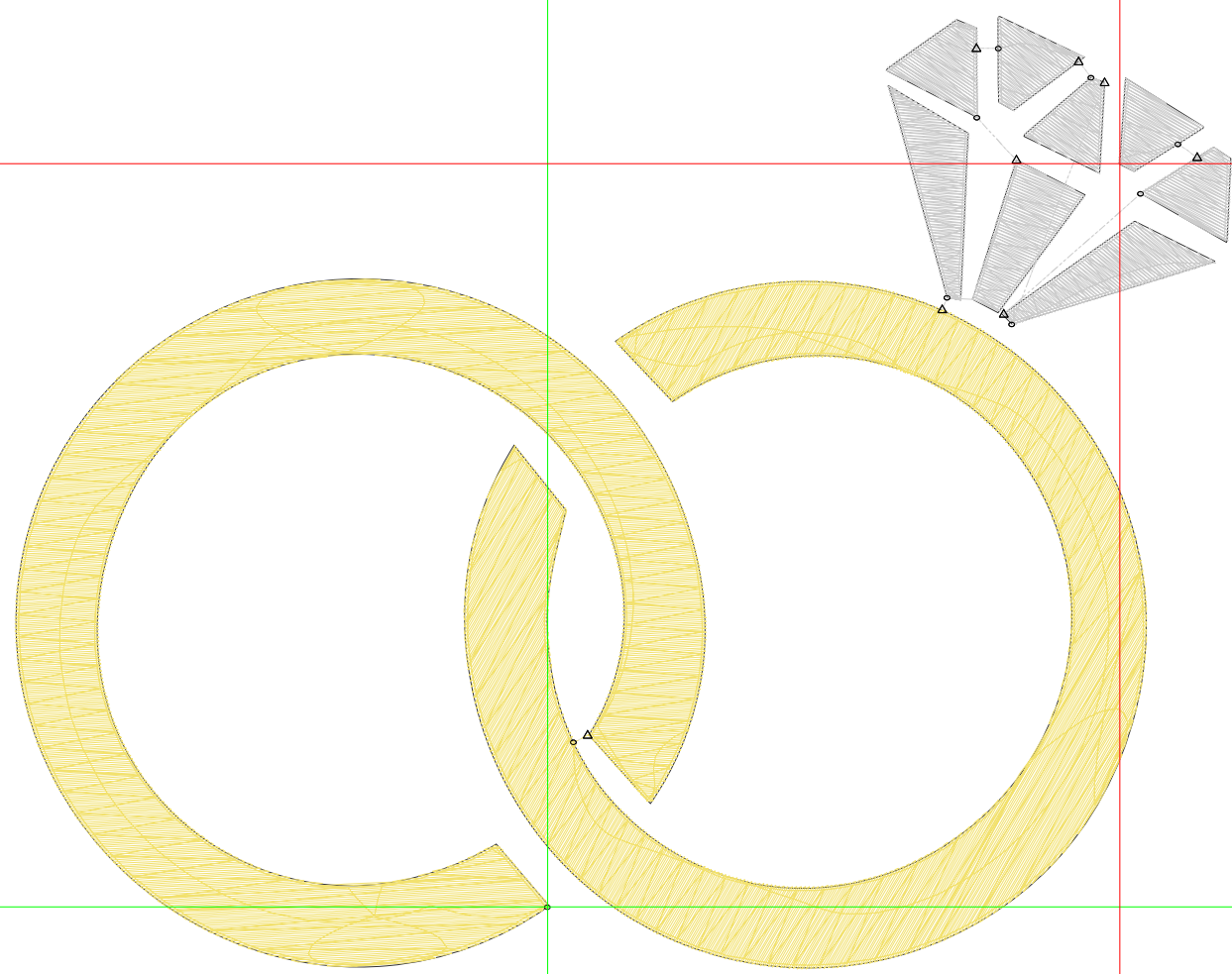

# Production Worksheet

Wilcom EmbroideryStudio - Designing

## \*06\*



Design: **06**

Title:

Stitches: 10,442  
 Height: 5.00 in  
 Width: 6.40 in  
 Colors: 2  
 Colorway: Colorway 1  
 Zoom: 1:1

Machine format: Tajima  
 Color changes: 1  
 Stops: 2  
 Trims: 8  
 Appliqués: 0  
 Left: 71.1 mm  
 Right: 91.3 mm  
 Up: 118.8 mm  
 Down: 8.3 mm  
 EndX: 3.01 in  
 EndY: 3.90 in  
 Area 31.99 in<sup>2</sup>  
 Max stitch: 6.9 mm  
 Min stitch: 0.1 mm  
 Max jump: 6.5 mm  
 Total thread: 205.69ft  
 Total bobbin: 80.90ft

Stop Sequence:

#	N#	Color	St.	Code	Name	Chart
1.	1		8,950	R242	G225 B110	
2.	3		1,490	R204	G204 B204	

# Color Film

Wilcom EmbroideryStudio - Designing

**\*06\***

Design: **06**

Title:

Stitches: 10,442  
Height: 5.00 in  
Width: 6.40 in  
Colors: 2  
Colorway: Colorway 1  
Zoom: 0.29

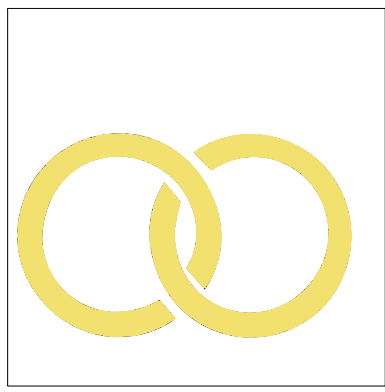

Stop #: 1  
Element:  
Code:  
Name: R242 G225 B110  
Chart:  
Stitches: 8,950  
Thread used: 170.50ft

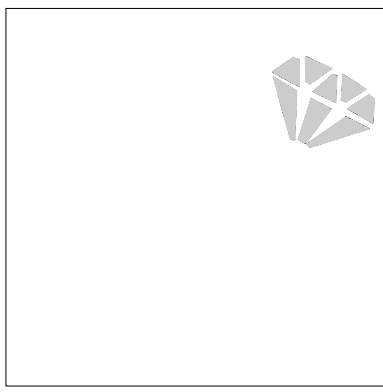

Stop #: 2  
Element:  
Code:  
Name: R204 G204 B204  
Chart:  
Stitches: 1,490  
Thread used: 34.53ft

# Production Worksheet

Wilcom EmbroideryStudio - Designing

\*06\*

Design: 06

Title:

Stitches: 14,048  
Height: 6.00 in  
Width: 7.67 in  
Colors: 2  
Colorway: Colorway 1  
Zoom: 1:1

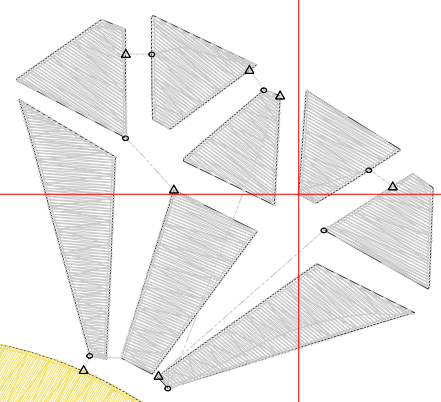
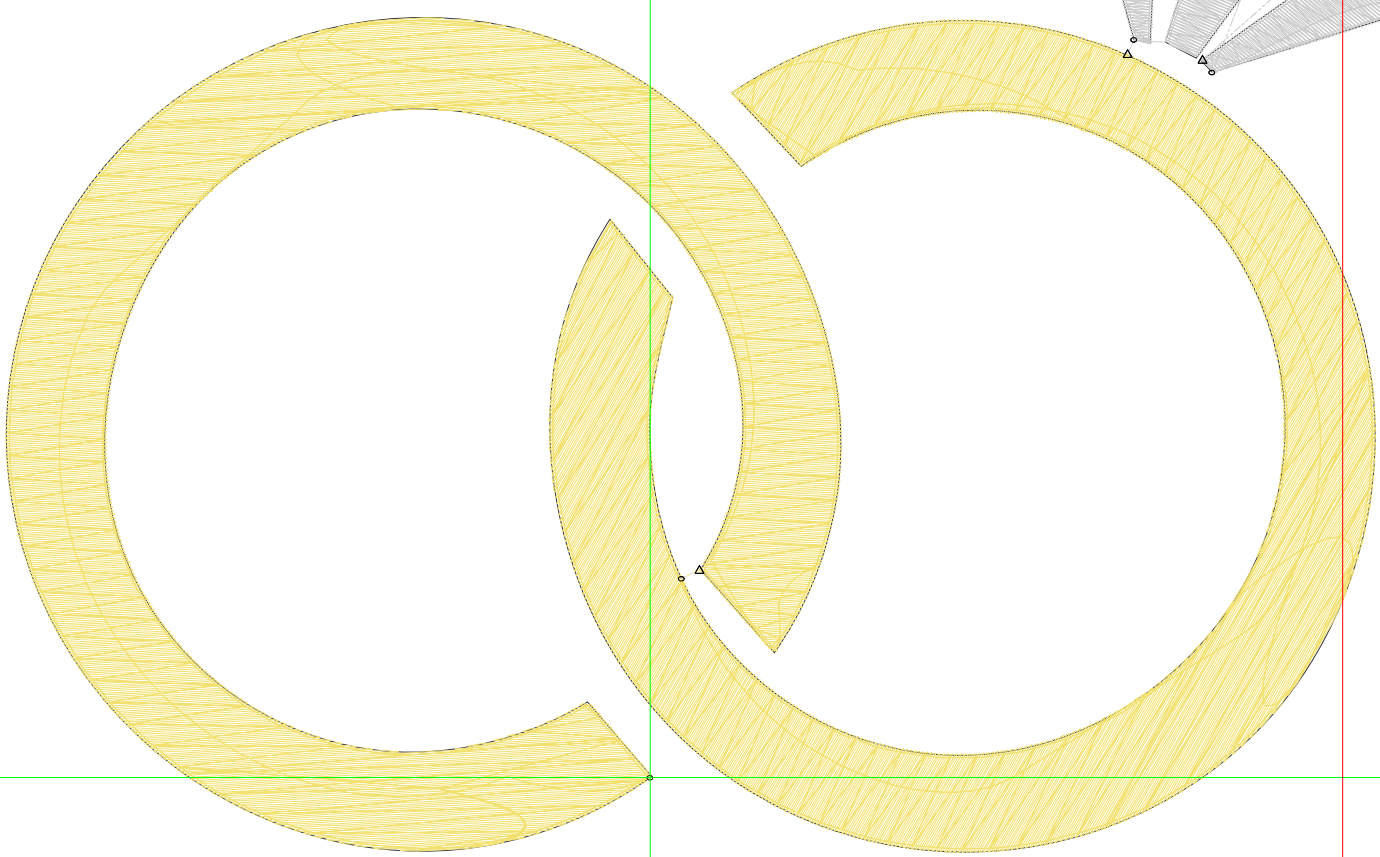

# Production Worksheet

Wilcom EmbroideryStudio - Designing

## \*06\*



Design: **06**

Title:

Stitches: 14,048  
 Height: 6.00 in  
 Width: 7.67 in  
 Colors: 2  
 Colorway: Colorway 1  
 Zoom: 1:1

Machine format: Tajima  
 Color changes: 1  
 Stops: 2  
 Trims: 8  
 Appliqués: 0  
 Left: 85.3 mm  
 Right: 109.6 mm  
 Up: 142.5 mm  
 Down: 9.9 mm  
 EndX: 3.61 in  
 EndY: 4.69 in  
 Area 46.06 in<sup>2</sup>  
 Max stitch: 6.9 mm  
 Min stitch: 0.1 mm  
 Max jump: 6.5 mm  
 Total thread: 286.53ft  
 Total bobbin: 114.78ft

Stop Sequence:

#	N#	Color	St.	Code	Name	Chart
1.	1		12,069		R242 G225 B110	
2.	3		1,977		R204 G204 B204	

# Color Film

Wilcom EmbroideryStudio - Designing

\*06\*

Design: 06

Title:

Stitches: 14,048  
Height: 6.00 in  
Width: 7.67 in  
Colors: 2  
Colorway: Colorway 1  
Zoom: 0.24

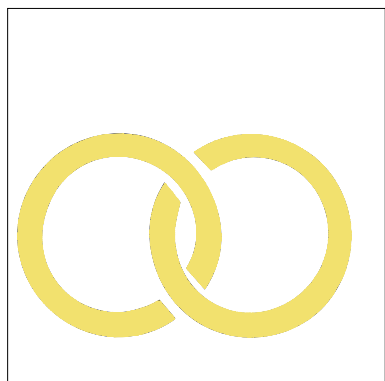

Stop #: 1  
Element:  
Code:  
Name: R242 G225 B110  
Chart:  
Stitches: 12,069  
Thread used: 238.07ft

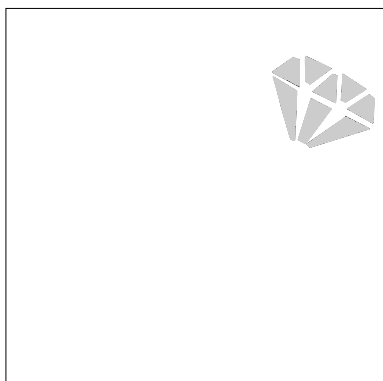

Stop #: 2  
Element:  
Code:  
Name: R204 G204 B204  
Chart:  
Stitches: 1,977  
Thread used: 47.81ft