



Creative Fabrica

**Embroidery Design
Sewing Information**

www.creativefabrica.com/embroidery/

© Creative Fabrica

Approval Sheet

Wilcom EmbroideryStudio - Designing

CONSTRUCTION MACHINERY EMBROIDERY DESIGN (2)

Design: **Construction Machinery Embroidery Design (2)**

Title:

Height: 1.23 in
Width: 2.27 in
Colors: 5
Colorway: Colorway 1
Zoom: 1:1



Product type:
Product:
Total qty:
Product colors:
Position:

Terms and Conditions:

Approved By:

Date:

Production Worksheet

Wilcom EmbroideryStudio - Designing

CONSTRUCTION MACHINERY EMBROIDERY DESIGN (2)





Design: **Construction Machinery Embroidery Design (2)**

Title:

Stitches: 3,169
 Height: 1.23 in
 Width: 2.27 in
 Colors: 5
 Colorway: Colorway 1
 Zoom: 1:1

Machine format: Tajima
 Color changes: 4
 Stops: 5
 Trims: 22
 Appliqués: 0
 Left: 15.5 mm
 Right: 42.1 mm
 Up: 26.3 mm
 Down: 5.0 mm
 EndX: 0.74 in
 EndY: 0.58 in
 Area 2.80 in²
 Max stitch: 10.6 mm
 Min stitch: 0.2 mm
 Max jump: 6.9 mm
 Total thread: 60.18ft
 Total bobbin: 22.37ft

Stop Sequence:

#	N#	Color	St.	Code	Name	Chart
1.	7		542		R23 G32 B34	
2.	6		571		R126 G132 B138	
3.	9		413		R57 G66 B68	
4.	3		1,050		R253 G191 B2	
5.	4		591		R215 G144 B1	

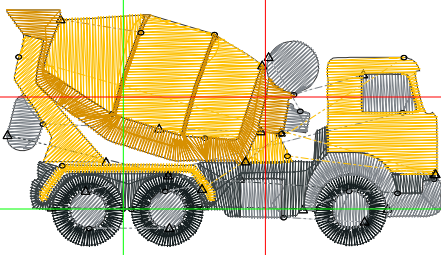

Approval Sheet

Wilcom EmbroideryStudio - Designing

CONSTRUCTION MACHINERY EMBROIDERY DESIGN (17)

Design: **Construction Machinery Embroidery Design (17)**

Title:

Height: 1.38 in
Width: 2.29 in
Colors: 4
Colorway: Colorway 1
Zoom: 1:1

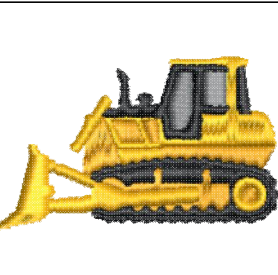
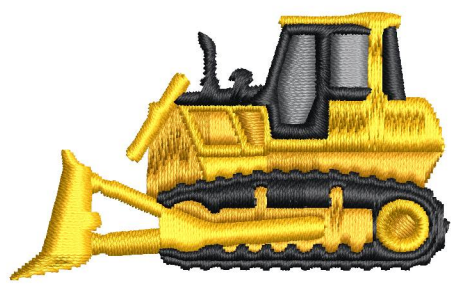

Product type:
Product:
Total qty:
Product colors:
Position:

Terms and Conditions:

Approved By:

Date:

Production Worksheet

Wilcom EmbroideryStudio - Designing

CONSTRUCTION MACHINERY EMBROIDERY DESIGN (17)





Design: **Construction Machinery Embroidery Design (17)**

Title:

Stitches: 3,427
Height: 1.38 in
Width: 2.29 in
Colors: 4
Colorway: Colorway 1
Zoom: 1:1

Machine format: Tajima
Color changes: 3
Stops: 4
Trims: 16
Appliqués: 0
Left: 40.0 mm
Right: 18.1 mm
Up: 13.2 mm
Down: 22.0 mm
EndX: 0.48 in
EndY: 0.07 in
Area 3.17 in²
Max stitch: 9.0 mm
Min stitch: 0.1 mm
Max jump: 6.8 mm
Total thread: 59.55ft
Total bobbin: 21.19ft

Stop Sequence:

#	N#	Color	St.	Code	Name	Chart
1.	4		135		R96 G106 B111	
2.	7		680		R225 G156 B6	
3.	5		1,174		R253 G191 B2	
4.	2		1,436		R14 G19 B23	

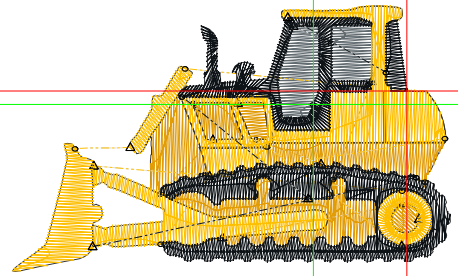

Approval Sheet

Wilcom EmbroideryStudio - Designing

CONSTRUCTION MACHINERY EMBROIDERY DESIGN (16)

Design: **Construction Machinery Embroidery Design (16)**

Title:

Height: 1.42 in
Width: 2.24 in
Colors: 4
Colorway: Colorway 1
Zoom: 1:1

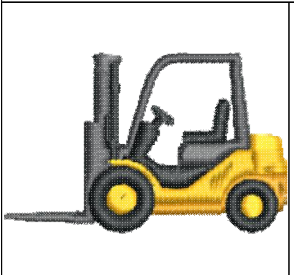

Product type:
Product:
Total qty:
Product colors:
Position:

Terms and Conditions:

Approved By:

Date:

Production Worksheet

Wilcom EmbroideryStudio - Designing

CONSTRUCTION MACHINERY EMBROIDERY DESIGN (16)





Design: **Construction Machinery Embroidery Design (16)**

Title:

Stitches: 2,276
 Height: 1.42 in
 Width: 2.24 in
 Colors: 4
 Colorway: Colorway 1
 Zoom: 1:1

Machine format: Tajima
 Color changes: 3
 Stops: 4
 Trims: 11
 Appliqués: 0
 Left: 56.7 mm
 Right: 0.2 mm
 Up: 24.2 mm
 Down: 11.8 mm
 EndX: -0.45 in
 EndY: 0.56 in
 Area 3.17 in²
 Max stitch: 8.6 mm
 Min stitch: 0.2 mm
 Max jump: 6.6 mm
 Total thread: 42.53ft
 Total bobbin: 15.58ft

Stop Sequence:

#	N#	Color	St.	Code	Name	Chart
1.	4		367	R253	G191 B2	
2.	5		180	R215	G144 B1	
3.	3		796	R68	G76 B80	
4.	7		931	R23	G32 B34	

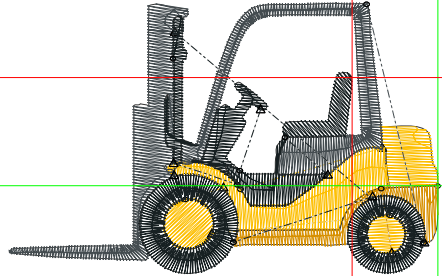

Approval Sheet

Wilcom EmbroideryStudio - Designing

CONSTRUCTION MACHINERY EMBROIDERY DESIGN (1)

Design: **Construction Machinery Embroidery Design (1)**

Title:

Height: 1.30 in
Width: 2.29 in
Colors: 5
Colorway: Colorway 1
Zoom: 1:1

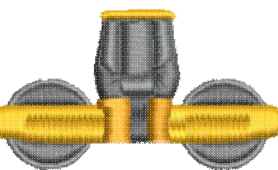
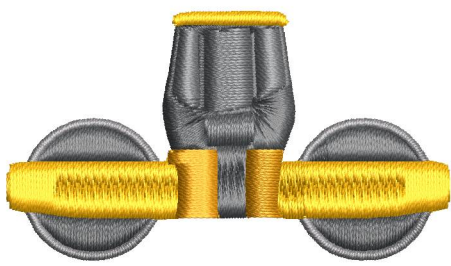

Product type:
Product:
Total qty:
Product colors:
Position:

Terms and Conditions:

Approved By:

Date:

Production Worksheet

Wilcom EmbroideryStudio - Designing

CONSTRUCTION MACHINERY EMBROIDERY DESIGN (1)





Design: **Construction Machinery Embroidery Design (1)**

Title:

Stitches: 2,381
 Height: 1.30 in
 Width: 2.29 in
 Colors: 5
 Colorway: Colorway 1
 Zoom: 1:1

Machine format: Tajima
 Color changes: 4
 Stops: 5
 Trims: 17
 Appliqués: 0
 Left: 3.0 mm
 Right: 55.2 mm
 Up: 26.3 mm
 Down: 6.6 mm
 EndX: 1.30 in
 EndY: 0.31 in
 Area: 2.97 in²
 Max stitch: 7.0 mm
 Min stitch: 0.1 mm
 Max jump: 6.9 mm
 Total thread: 46.15ft
 Total bobbin: 17.12ft

Stop Sequence:

#	N#	Color	St.	Code	Name	Chart
1.	2		908		R68 G76 B80	
2.	3		266		R96 G106 B111	
3.	7		527		R126 G132 B138	
4.	4		556		R253 G191 B2	
5.	5		122		R215 G144 B1	

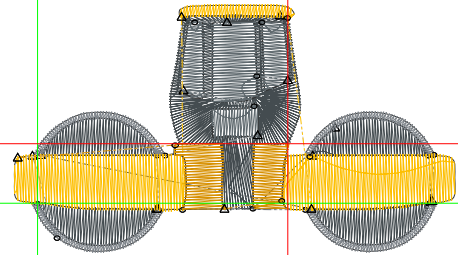

Approval Sheet

Wilcom EmbroideryStudio - Designing

CONSTRUCTION MACHINERY EMBROIDERY DESIGN (3)

Design: **Construction Machinery Embroidery Design (3)**

Title:

Height: 1.48 in
Width: 1.57 in
Colors: 3
Colorway: Colorway 1
Zoom: 1:1

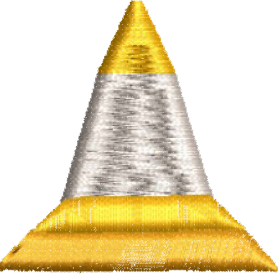
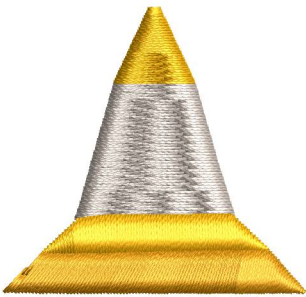

Product type:
Product:
Total qty:
Product colors:
Position:

Terms and Conditions:

Approved By:

Date:

Production Worksheet

Wilcom EmbroideryStudio - Designing

CONSTRUCTION MACHINERY EMBROIDERY DESIGN (3)



Design: **Construction Machinery Embroidery Design (3)**

Title:

Stitches: 825
 Height: 1.48 in
 Width: 1.57 in
 Colors: 3
 Colorway: Colorway 1
 Zoom: 1:1

Machine format: Tajima
 Color changes: 2
 Stops: 3
 Trims: 3
 Appliqués: 0
 Left: 9.3 mm
 Right: 30.4 mm
 Up: 27.7 mm
 Down: 9.9 mm
 EndX: 0.89 in
 EndY: -0.16 in
 Area: 2.32 in²
 Max stitch: 7.0 mm
 Min stitch: 0.2 mm
 Max jump: 6.6 mm
 Total thread: 23.20ft
 Total bobbin: 9.96ft

Stop Sequence:

#	N#	Color	St.	Code	Name	Chart
1.	4		319		R207 G205 B198	
2.	2		283		R253 G191 B2	
3.	3		221		R225 G156 B6	

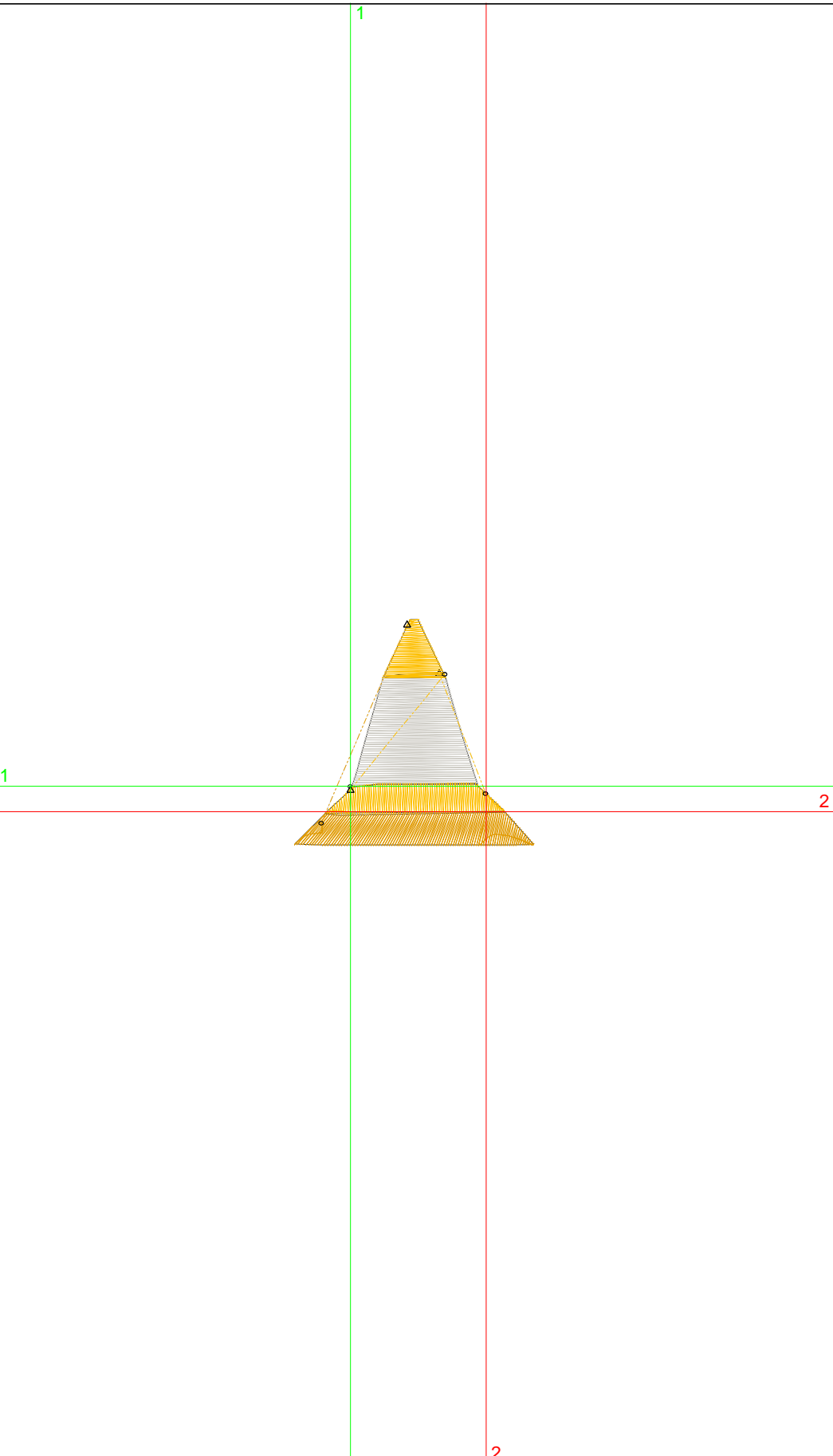

Approval Sheet

Wilcom EmbroideryStudio - Designing

CONSTRUCTION MACHINERY EMBROIDERY DESIGN (4)

Design: **Construction Machinery Embroidery Design (4)**

Title:

Height: 0.84 in
Width: 2.27 in
Colors: 1
Colorway: Colorway 1
Zoom: 1:1

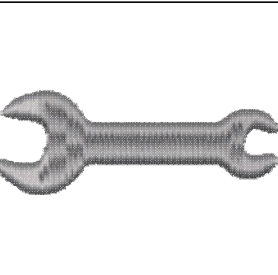
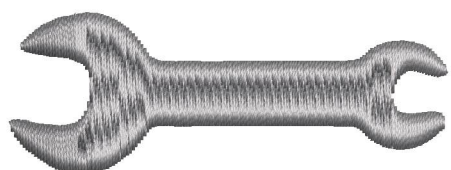

Product type:
Product:
Total qty:
Product colors:
Position:

Terms and Conditions:

Approved By:

Date:

Production Worksheet

Wilcom EmbroideryStudio - Designing

CONSTRUCTION MACHINERY EMBROIDERY DESIGN (4)

Design: **Construction Machinery Embroidery Design (4)**

Title:

Stitches: 759
Height: 0.84 in
Width: 2.27 in
Colors: 1
Colorway: Colorway 1
Zoom: 1:1

Machine format: Tajima
Color changes: 0
Stops: 1
Trims: 0
Appliqués: 0
Left: 54.3 mm
Right: 3.4 mm
Up: 17.3 mm
Down: 3.9 mm
EndX: -1.80 in
EndY: 0.67 in
Area 1.90 in²
Max stitch: 7.0 mm
Min stitch: 0.2 mm
Max jump: 0.0 mm
Total thread: 19.50ft
Total bobbin: 8.41ft

Stop Sequence:

#	N#	Color	St.	Code	Name	Chart
1.	2		757		R126 G132 B138	

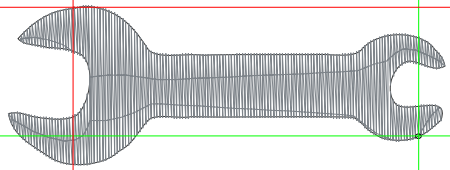

Approval Sheet

Wilcom EmbroideryStudio - Designing

CONSTRUCTION MACHINERY EMBROIDERY DESIGN (5)

Design: **Construction Machinery Embroidery Design (5)**

Title:

Height: 1.48 in
Width: 0.88 in
Colors: 2
Colorway: Colorway 1
Zoom: 1:1

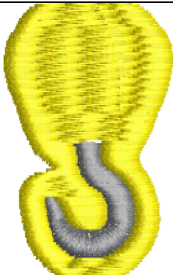
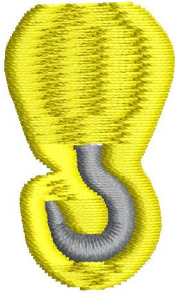

Product type:
Product:
Total qty:
Product colors:
Position:

Terms and Conditions:

Approved By:

Date:

Production Worksheet

Wilcom EmbroideryStudio - Designing

CONSTRUCTION MACHINERY EMBROIDERY DESIGN (5)



Design: **Construction Machinery Embroidery Design (5)**

Title:

Stitches: 833
 Height: 1.48 in
 Width: 0.88 in
 Colors: 2
 Colorway: Colorway 1
 Zoom: 1:1

Machine format: Tajima
 Color changes: 1
 Stops: 2
 Trims: 1
 Appliqués: 0
 Left: 9.6 mm
 Right: 12.8 mm
 Up: 18.6 mm
 Down: 19.0 mm
 EndX: 0.16 in
 EndY: 0.73 in
 Area: 1.30 in²
 Max stitch: 7.0 mm
 Min stitch: 0.2 mm
 Max jump: 0.0 mm
 Total thread: 22.56ft
 Total bobbin: 9.74ft

Stop Sequence:

#	N#	Color	St.	Code	Name	Chart
1.	2		184		R96 G106 B111	
2.	4		647	4	Yellow	Default

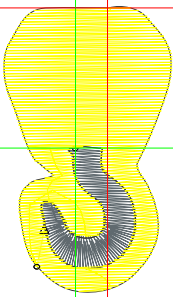

Approval Sheet

Wilcom EmbroideryStudio - Designing

CONSTRUCTION MACHINERY EMBROIDERY DESIGN (6)

Design: **Construction Machinery Embroidery Design (6)**

Title:

Height: 1.53 in
Width: 1.95 in
Colors: 5
Colorway: Colorway 1
Zoom: 1:1

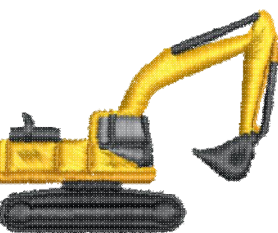

Product type:
Product:
Total qty:
Product colors:
Position:

Terms and Conditions:

Approved By:

Date:

Production Worksheet

Wilcom EmbroideryStudio - Designing

CONSTRUCTION MACHINERY EMBROIDERY DESIGN (6)

Design: **Construction Machinery Embroidery Design (6)**

Title:

Stitches: 2,758
 Height: 1.53 in
 Width: 1.95 in
 Colors: 5
 Colorway: Colorway 1
 Zoom: 1:1

Machine format: Tajima
 Color changes: 4
 Stops: 5
 Trims: 12
 Appliqués: 0
 Left: 23.9 mm
 Right: 25.6 mm
 Up: 23.4 mm
 Down: 15.5 mm
 EndX: -0.01 in
 EndY: -0.57 in
 Area 2.99 in²
 Max stitch: 10.8 mm
 Min stitch: 0.2 mm
 Max jump: 6.8 mm
 Total thread: 44.64ft
 Total bobbin: 14.76ft

Stop Sequence:

#	N#	Color	St.	Code	Name	Chart
1.	4		142		R96 G106 B111	
2.	5		650		R253 G191 B2	
3.	6		406		R215 G144 B1	
4.	3		1,131		R40 G48 B51	
5.	2		427		R14 G19 B23	

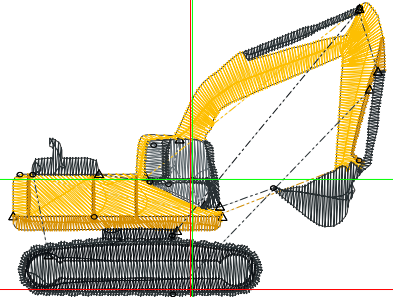

Approval Sheet

Wilcom EmbroideryStudio - Designing

CONSTRUCTION MACHINERY EMBROIDERY DESIGN (7)

Design: **Construction Machinery Embroidery Design (7)**

Title:

Height: 0.79 in
Width: 2.28 in
Colors: 2
Colorway: Colorway 1
Zoom: 1:1

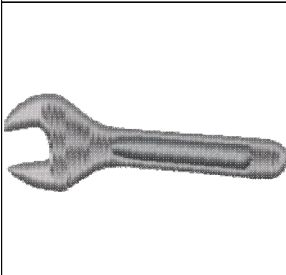

Product type:
Product:
Total qty:
Product colors:
Position:

Terms and Conditions:

Approved By:

Date:

Production Worksheet

Wilcom EmbroideryStudio - Designing

CONSTRUCTION MACHINERY EMBROIDERY DESIGN (7)

Design: **Construction Machinery Embroidery Design (7)**

Title:

Stitches: 907
 Height: 0.79 in
 Width: 2.28 in
 Colors: 2
 Colorway: Colorway 1
 Zoom: 1:1

Machine format: Tajima
 Color changes: 1
 Stops: 2
 Trims: 1
 Appliqués: 0
 Left: 27.8 mm
 Right: 30.1 mm
 Up: 15.0 mm
 Down: 5.1 mm
 EndX: 0.85 in
 EndY: -0.02 in
 Area: 1.80 in²
 Max stitch: 7.0 mm
 Min stitch: 0.2 mm
 Max jump: 5.3 mm
 Total thread: 20.56ft
 Total bobbin: 8.27ft

Stop Sequence:

#	N#	Color	St.	Code	Name	Chart
1.	3		737	R126	G132 B138	
2.	2		168	R96	G106 B111	

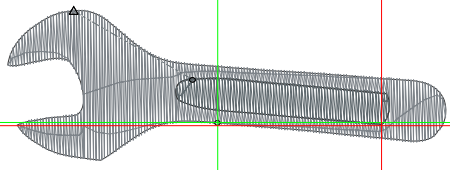

Approval Sheet

Wilcom EmbroideryStudio - Designing

CONSTRUCTION MACHINERY EMBROIDERY DESIGN (8)

Design: **Construction Machinery Embroidery Design (8)**

Title:

Height: 1.51 in
Width: 0.60 in
Colors: 2
Colorway: Colorway 1
Zoom: 1:1



Product type:
Product:
Total qty:
Product colors:
Position:

Terms and Conditions:

Approved By:

Date:

Production Worksheet

Wilcom EmbroideryStudio - Designing

CONSTRUCTION MACHINERY EMBROIDERY DESIGN (8)



Design: **Construction Machinery Embroidery Design (8)**

Title:

Stitches: 289
 Height: 1.51 in
 Width: 0.60 in
 Colors: 2
 Colorway: Colorway 1
 Zoom: 1:1

Machine format: Tajima
 Color changes: 1
 Stops: 2
 Trims: 1
 Appliqués: 0
 Left: 4.7 mm
 Right: 10.5 mm
 Up: 37.9 mm
 Down: 0.6 mm
 EndX: 0.16 in
 EndY: 1.49 in
 Area: 0.91 in²
 Max stitch: 5.8 mm
 Min stitch: 0.2 mm
 Max jump: 0.0 mm
 Total thread: 7.56ft
 Total bobbin: 2.97ft

Stop Sequence:

#	N#	Color	St.	Code	Name	Chart
1.	3		182		R253 G191 B2	
2.	2		105		R89 G98 B101	

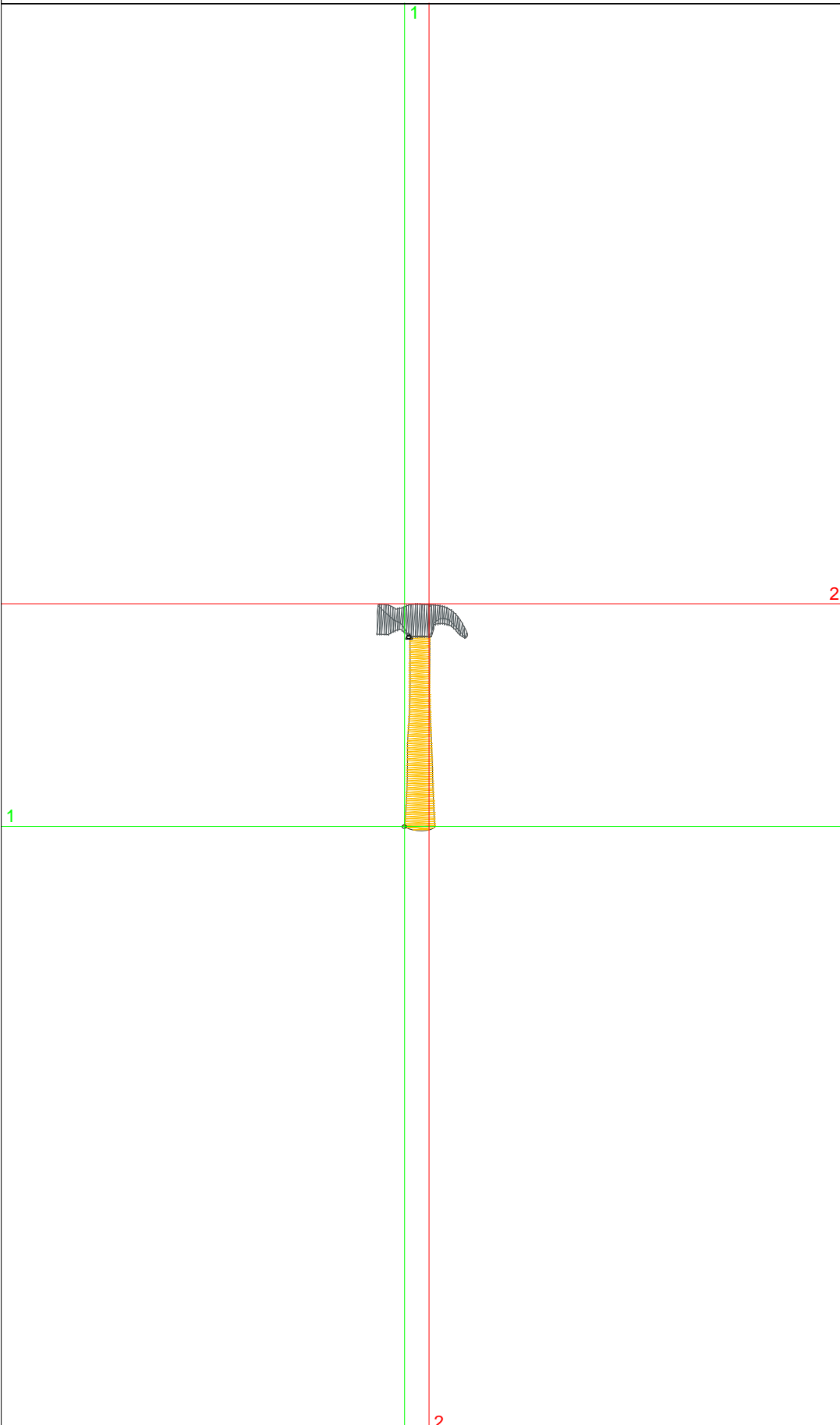

Approval Sheet

Wilcom EmbroideryStudio - Designing

CONSTRUCTION MACHINERY EMBROIDERY DESIGN (9)

Design: **Construction Machinery Embroidery Design (9)**

Title:

Height: 1.51 in
Width: 2.28 in
Colors: 3
Colorway: Colorway 1
Zoom: 1:1



Product type:
Product:
Total qty:
Product colors:
Position:

Terms and Conditions:

Approved By:

Date:

Production Worksheet

Wilcom EmbroideryStudio - Designing

CONSTRUCTION MACHINERY EMBROIDERY DESIGN (9)



Design: **Construction Machinery Embroidery Design (9)**

Title:

Stitches: 2,018
 Height: 1.51 in
 Width: 2.28 in
 Colors: 3
 Colorway: Colorway 1
 Zoom: 1:1

Machine format: Tajima
 Color changes: 2
 Stops: 3
 Trims: 7
 Appliqués: 0
 Left: 47.5 mm
 Right: 10.4 mm
 Up: 0.7 mm
 Down: 37.6 mm
 EndX: -1.68 in
 EndY: -1.18 in
 Area: 3.44 in²
 Max stitch: 11.8 mm
 Min stitch: 0.3 mm
 Max jump: 6.9 mm
 Total thread: 49.15ft
 Total bobbin: 20.69ft

Stop Sequence:

#	N#	Color	St.	Code	Name	Chart
1.	3		1,078		R253 G191 B2	
2.	5		572		R86 G88 B75	
3.	4		366		R57 G66 B68	

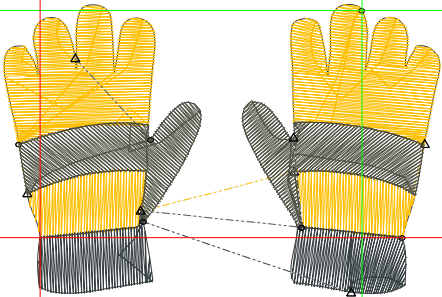

Approval Sheet

Wilcom EmbroideryStudio - Designing

CONSTRUCTION MACHINERY EMBROIDERY DESIGN (10)

Design: **Construction Machinery Embroidery Design (10)**

Title:

Height: 0.63 in
Width: 2.20 in
Colors: 2
Colorway: Colorway 1
Zoom: 1:1

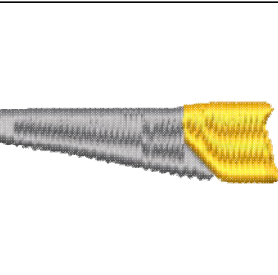
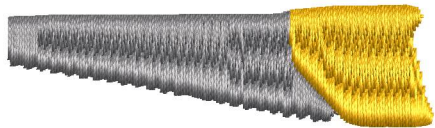

Product type:
Product:
Total qty:
Product colors:
Position:

Terms and Conditions:

Approved By:

Date:

Production Worksheet

Wilcom EmbroideryStudio - Designing

CONSTRUCTION MACHINERY EMBROIDERY DESIGN (10)



Design: **Construction Machinery Embroidery Design (10)**

Title:

Stitches: 792
Height: 0.63 in
Width: 2.20 in
Colors: 2
Colorway: Colorway 1
Zoom: 1:1

Machine format: Tajima
Color changes: 1
Stops: 2
Trims: 1
Appliqués: 0
Left: 14.3 mm
Right: 41.6 mm
Up: 9.8 mm
Down: 6.3 mm
EndX: 1.59 in
EndY: 0.33 in
Area 1.40 in²
Max stitch: 7.0 mm
Min stitch: 0.2 mm
Max jump: 0.0 mm
Total thread: 21.49ft
Total bobbin: 9.26ft

Stop Sequence:

#	N#	Color	St.	Code	Name	Chart
1.	3		492	R126	G132 B138	
2.	2		298	R253	G191 B2	

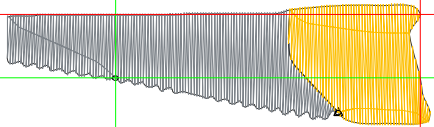

Approval Sheet

Wilcom EmbroideryStudio - Designing

CONSTRUCTION MACHINERY EMBROIDERY DESIGN (11)

Design: **Construction Machinery Embroidery Design (11)**

Title:

Height: 1.38 in
Width: 0.75 in
Colors: 2
Colorway: Colorway 1
Zoom: 1:1

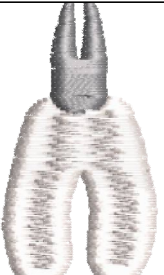
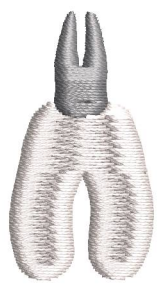

Product type:
Product:
Total qty:
Product colors:
Position:

Terms and Conditions:

Approved By:

Date:

Production Worksheet

Wilcom EmbroideryStudio - Designing

CONSTRUCTION MACHINERY EMBROIDERY DESIGN (11)



Design: **Construction Machinery Embroidery Design (11)**

Title:

Stitches: 585
 Height: 1.38 in
 Width: 0.75 in
 Colors: 2
 Colorway: Colorway 1
 Zoom: 1:1

Machine format: Tajima
 Color changes: 1
 Stops: 2
 Trims: 1
 Appliqués: 0
 Left: 10.4 mm
 Right: 8.6 mm
 Up: 23.0 mm
 Down: 12.2 mm
 EndX: 0.09 in
 EndY: 0.55 in
 Area: 1.04 in²
 Max stitch: 11.5 mm
 Min stitch: 0.2 mm
 Max jump: 0.0 mm
 Total thread: 14.74ft
 Total bobbin: 6.07ft

Stop Sequence:

#	N#	Color	St.	Code	Name	Chart
1.	9		447	9	White	Default
2.	2		136		R126 G132 B138	

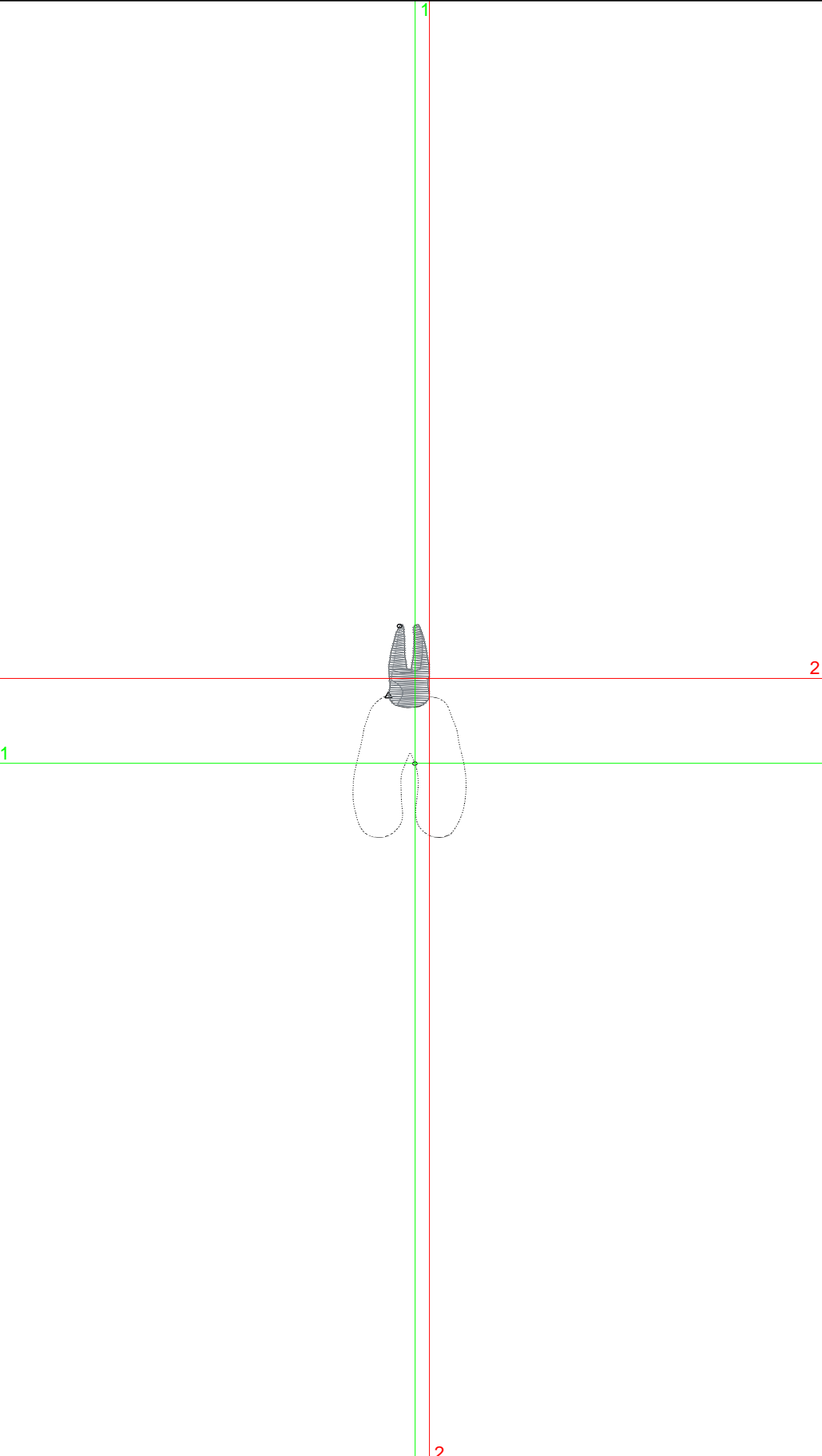

Approval Sheet

Wilcom EmbroideryStudio - Designing

CONSTRUCTION MACHINERY EMBROIDERY DESIGN (12)

Design: **Construction Machinery Embroidery Design (12)**

Title:

Height: 1.45 in
Width: 2.23 in
Colors: 3
Colorway: Colorway 1
Zoom: 1:1

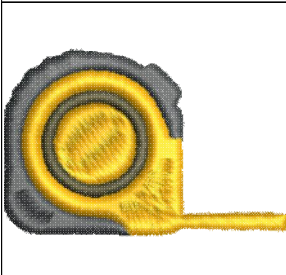

Product type:
Product:
Total qty:
Product colors:
Position:

Terms and Conditions:

Approved By:

Date:

Production Worksheet

Wilcom EmbroideryStudio - Designing

CONSTRUCTION MACHINERY EMBROIDERY DESIGN (12)



Design: **Construction Machinery Embroidery Design (12)**

Title:

Stitches: 2,064
 Height: 1.45 in
 Width: 2.23 in
 Colors: 3
 Colorway: Colorway 1
 Zoom: 1:1

Machine format: Tajima
 Color changes: 2
 Stops: 3
 Trims: 3
 Appliqués: 0
 Left: 25.8 mm
 Right: 30.8 mm
 Up: 36.7 mm
 Down: 0.2 mm
 EndX: -0.06 in
 EndY: 1.24 in
 Area 3.23 in²
 Max stitch: 7.0 mm
 Min stitch: 0.2 mm
 Max jump: 5.5 mm
 Total thread: 51.42ft
 Total bobbin: 21.86ft

Stop Sequence:

#	N#	Color	St.	Code	Name	Chart
1.	3		578		R57 G66 B68	
2.	4		426		R51 G52 B23	
3.	2		1,058		R253 G191 B2	

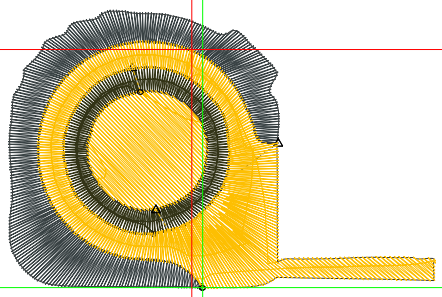

Approval Sheet

Wilcom EmbroideryStudio - Designing

CONSTRUCTION MACHINERY EMBROIDERY DESIGN (13)

Design: **Construction Machinery Embroidery Design (13)**

Title:

Height: 1.51 in
Width: 0.38 in
Colors: 2
Colorway: Colorway 1
Zoom: 1:1



Product type:
Product:
Total qty:
Product colors:
Position:

Terms and Conditions:

Approved By:

Date:

Production Worksheet

Wilcom EmbroideryStudio - Designing

CONSTRUCTION MACHINERY EMBROIDERY DESIGN (13)



Design: **Construction Machinery Embroidery Design (13)**

Title:

Stitches: 299
Height: 1.51 in
Width: 0.38 in
Colors: 2
Colorway: Colorway 1
Zoom: 1:1

Machine format: Tajima
Color changes: 1
Stops: 2
Trims: 2
Appliqués: 0
Left: 4.7 mm
Right: 4.9 mm
Up: 38.4 mm
Down: 0.0 mm
EndX: 0.04 in
EndY: 0.56 in
Area 0.57 in²
Max stitch: 7.3 mm
Min stitch: 0.2 mm
Max jump: 5.3 mm
Total thread: 6.84ft
Total bobbin: 2.50ft

Stop Sequence:

#	N#	Color	St.	Code	Name	Chart
1.	2		194	R96	G106 B111	
2.	3		103	R253	G191 B2	

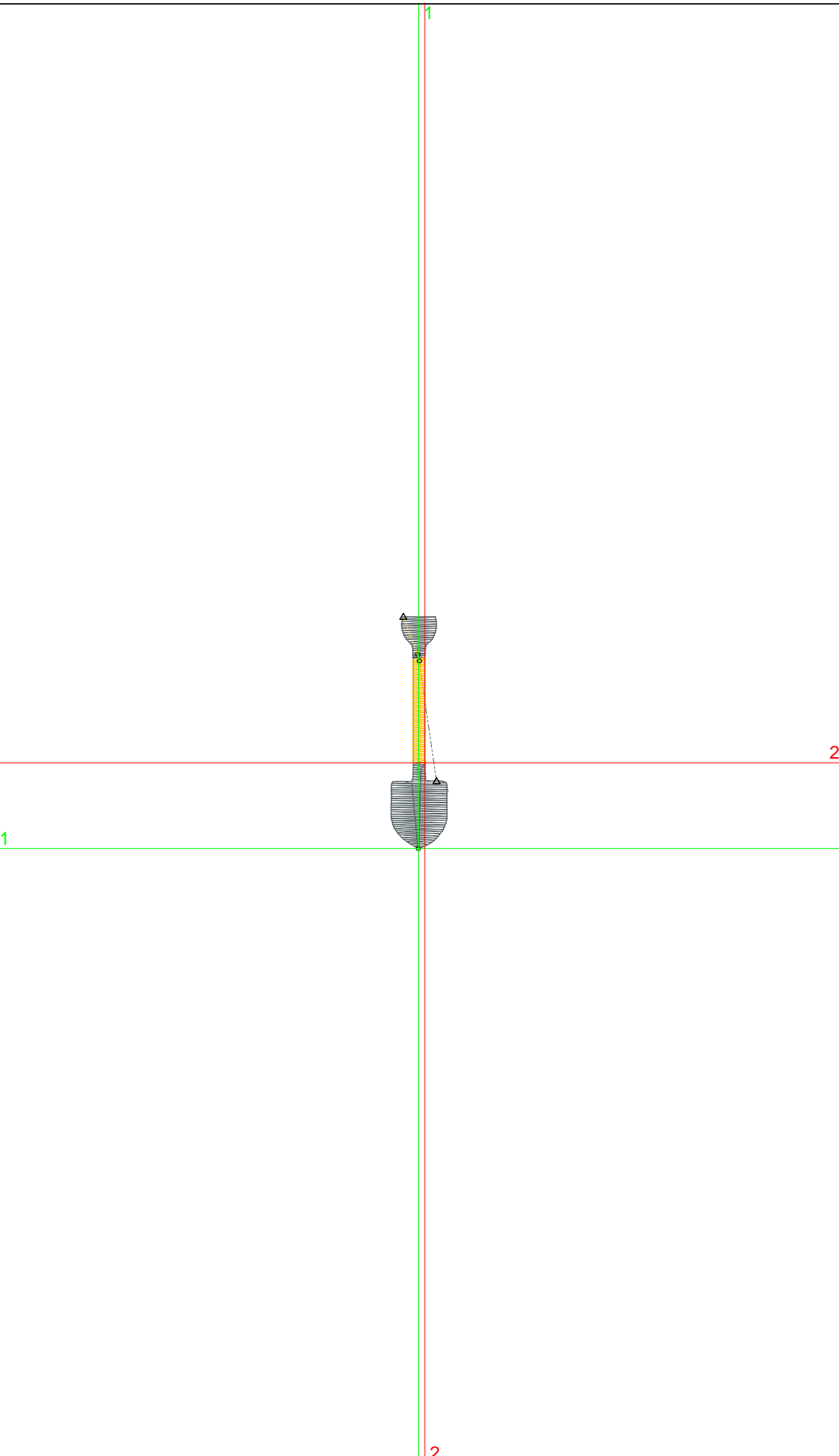

Approval Sheet

Wilcom EmbroideryStudio - Designing

CONSTRUCTION MACHINERY EMBROIDERY DESIGN (14)

Design: **Construction Machinery Embroidery Design (14)**

Title:

Height: 1.52 in
Width: 1.10 in
Colors: 2
Colorway: Colorway 1
Zoom: 1:1

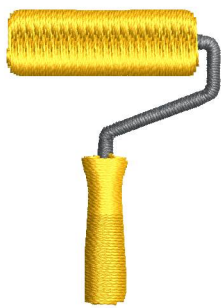

Product type:
Product:
Total qty:
Product colors:
Position:

Terms and Conditions:

Approved By:

Date:

Production Worksheet

Wilcom EmbroideryStudio - Designing

CONSTRUCTION MACHINERY EMBROIDERY DESIGN (14)

Design: **Construction Machinery Embroidery Design (14)**

Title:

Stitches: 578
Height: 1.52 in
Width: 1.10 in
Colors: 2
Colorway: Colorway 1
Zoom: 1:1

Machine format: Tajima
Color changes: 1
Stops: 2
Trims: 2
Appliqués: 0
Left: 13.9 mm
Right: 14.2 mm
Up: 19.0 mm
Down: 19.7 mm
EndX: 0.05 in
EndY: -0.31 in
Area 1.68 in²
Max stitch: 6.4 mm
Min stitch: 0.2 mm
Max jump: 3.6 mm
Total thread: 13.15ft
Total bobbin: 5.16ft

Stop Sequence:

#	N#	Color	St.	Code	Name	Chart
1.	2		171	R96	G106 B111	
2.	3		405	R253	G191 B2	

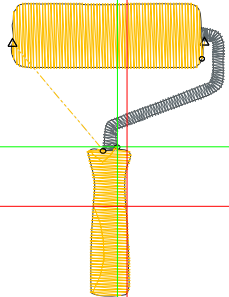

1

2

2

Approval Sheet

Wilcom EmbroideryStudio - Designing

CONSTRUCTION MACHINERY EMBROIDERY DESIGN (15)

Design: **Construction Machinery Embroidery Design (15)**

Title:

Height: 0.89 in
Width: 2.21 in
Colors: 3
Colorway: Colorway 1
Zoom: 1:1

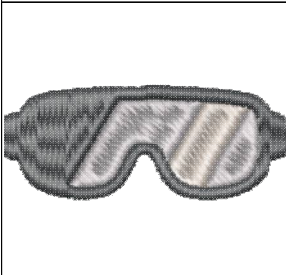
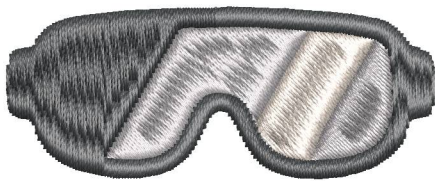

Product type:
Product:
Total qty:
Product colors:
Position:

Terms and Conditions:

Approved By:

Date:

Production Worksheet

Wilcom EmbroideryStudio - Designing

CONSTRUCTION MACHINERY EMBROIDERY DESIGN (15)

Design: **Construction Machinery Embroidery Design (15)**

Title:

Stitches: 1,490
 Height: 0.89 in
 Width: 2.21 in
 Colors: 3
 Colorway: Colorway 1
 Zoom: 1:1

Machine format: Tajima
 Color changes: 3
 Stops: 4
 Trims: 3
 Appliqués: 0
 Left: 39.7 mm
 Right: 16.4 mm
 Up: 20.5 mm
 Down: 2.2 mm
 EndX: -0.49 in
 EndY: 0.80 in
 Area: 1.97 in²
 Max stitch: 9.5 mm
 Min stitch: 0.2 mm
 Max jump: 5.3 mm
 Total thread: 36.82ft
 Total bobbin: 15.25ft

Stop Sequence:

#	N#	Color	St.	Code	Name	Chart
1.	4		138		R163 G168 B174	
2.	3		206		R207 G205 B198	
3.	4		328		R163 G168 B174	
4.	2		816		R68 G76 B80	

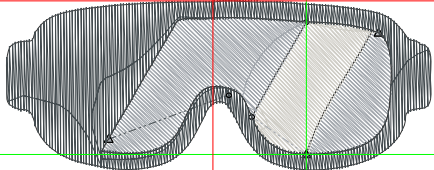

Approval Sheet

Wilcom EmbroideryStudio - Designing

CONSTRUCTION MACHINERY EMBROIDERY DESIGN (18)

Design: **Construction Machinery Embroidery Design (18)**

Title:

Height: 0.88 in
Width: 2.32 in
Colors: 4
Colorway: Colorway 1
Zoom: 1:1

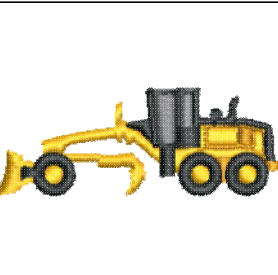
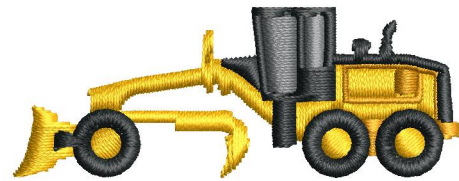

Product type:
Product:
Total qty:
Product colors:
Position:

Terms and Conditions:

Approved By:

Date:

Production Worksheet

Wilcom EmbroideryStudio - Designing

CONSTRUCTION MACHINERY EMBROIDERY DESIGN (18)





Design: **Construction Machinery Embroidery Design (18)**

Title:

Stitches: 2,065
Height: 0.88 in
Width: 2.32 in
Colors: 4
Colorway: Colorway 1
Zoom: 1:1

Machine format: Tajima
Color changes: 3
Stops: 4
Trims: 13
Appliqués: 0
Left: 49.4 mm
Right: 9.5 mm
Up: 7.5 mm
Down: 14.8 mm
EndX: -0.11 in
EndY: -0.48 in
Area 2.03 in²
Max stitch: 7.2 mm
Min stitch: 0.1 mm
Max jump: 6.5 mm
Total thread: 34.82ft
Total bobbin: 11.83ft

Stop Sequence:

#	N#	Color	St.	Code	Name	Chart
1.	4		690		R253 G191 B2	
2.	5		300		R215 G144 B1	
3.	3		133		R96 G106 B111	
4.	8		940		R23 G32 B34	

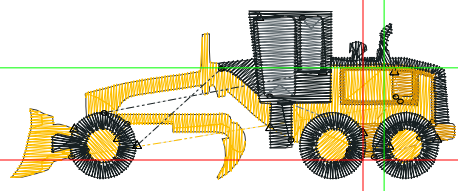

Approval Sheet

Wilcom EmbroideryStudio - Designing

CONSTRUCTION MACHINERY EMBROIDERY DESIGN (19)

Design: **Construction Machinery Embroidery Design (19)**

Title:

Height: 1.49 in
Width: 1.13 in
Colors: 3
Colorway: Colorway 1
Zoom: 1:1

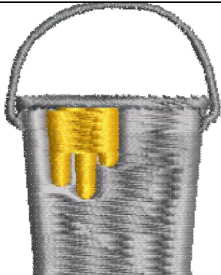

Product type:
Product:
Total qty:
Product colors:
Position:

Terms and Conditions:

Approved By:

Date:

Production Worksheet

Wilcom EmbroideryStudio - Designing

CONSTRUCTION MACHINERY EMBROIDERY DESIGN (19)



Design: **Construction Machinery Embroidery Design (19)**

Title:

Stitches: 1,126
 Height: 1.49 in
 Width: 1.13 in
 Colors: 3
 Colorway: Colorway 1
 Zoom: 1:1

Machine format: Tajima
 Color changes: 2
 Stops: 3
 Trims: 2
 Appliqués: 0
 Left: 5.9 mm
 Right: 22.7 mm
 Up: 14.4 mm
 Down: 23.4 mm
 EndX: 0.35 in
 EndY: 0.00 in
 Area: 1.68 in²
 Max stitch: 7.5 mm
 Min stitch: 0.0 mm
 Max jump: 6.2 mm
 Total thread: 25.01ft
 Total bobbin: 9.86ft

Stop Sequence:

#	N#	Color	St.	Code	Name	Chart
1.	4		596		R126 G132 B138	
2.	2		371		R96 G106 B111	
3.	3		157		R253 G191 B2	

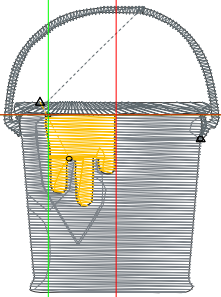

Approval Sheet

Wilcom EmbroideryStudio - Designing

CONSTRUCTION MACHINERY EMBROIDERY DESIGN (20)

Design: **Construction Machinery Embroidery Design (20)**

Title:

Height: 1.40 in
Width: 2.27 in
Colors: 5
Colorway: Colorway 1
Zoom: 1:1

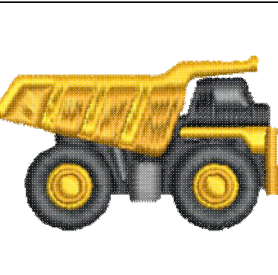

Product type:
Product:
Total qty:
Product colors:
Position:

Terms and Conditions:

Approved By:

Date:

Production Worksheet

Wilcom EmbroideryStudio - Designing

CONSTRUCTION MACHINERY EMBROIDERY DESIGN (20)





Design: **Construction Machinery Embroidery Design (20)**

Title:

Stitches: 3,301
 Height: 1.40 in
 Width: 2.27 in
 Colors: 5
 Colorway: Colorway 1
 Zoom: 1:1

Machine format: Tajima
 Color changes: 4
 Stops: 5
 Trims: 17
 Appliqués: 0
 Left: 36.2 mm
 Right: 21.5 mm
 Up: 28.1 mm
 Down: 7.5 mm
 EndX: -1.19 in
 EndY: 0.86 in
 Area 3.18 in²
 Max stitch: 7.9 mm
 Min stitch: 0.2 mm
 Max jump: 6.7 mm
 Total thread: 66.77ft
 Total bobbin: 25.76ft

Stop Sequence:

#	N#	Color	St.	Code	Name	Chart
1.	2		590		R14 G19 B23	
2.	3		678		R40 G48 B51	
3.	4		172		R89 G98 B101	
4.	7		1,045		R253 G191 B2	
5.	9		814		R225 G156 B6	

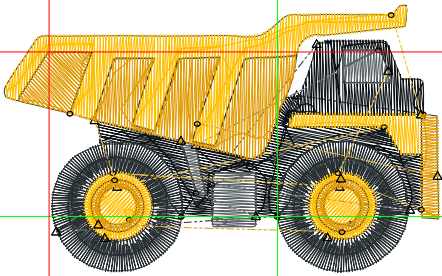

Approval Sheet

Wilcom EmbroideryStudio - Designing

CONSTRUCTION MACHINERY EMBROIDERY DESIGN (21)

Design: **Construction Machinery Embroidery Design (21)**

Title:

Height: 1.35 in
Width: 2.20 in
Colors: 2
Colorway: Colorway 1
Zoom: 1:1

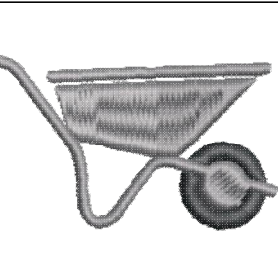
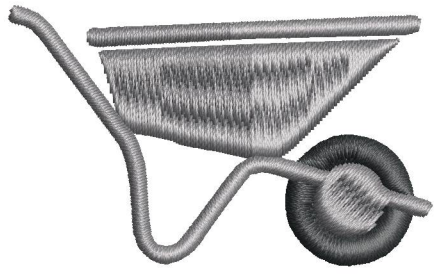

Product type:
Product:
Total qty:
Product colors:
Position:

Terms and Conditions:

Approved By:

Date:

Production Worksheet

Wilcom EmbroideryStudio - Designing

CONSTRUCTION MACHINERY EMBROIDERY DESIGN (21)

Design: **Construction Machinery Embroidery Design (21)**

Title:

Stitches: 1,581
 Height: 1.35 in
 Width: 2.20 in
 Colors: 2
 Colorway: Colorway 1
 Zoom: 1:1

Machine format: Tajima
 Color changes: 2
 Stops: 3
 Trims: 4
 Appliqués: 0
 Left: 14.6 mm
 Right: 41.3 mm
 Up: 14.9 mm
 Down: 19.4 mm
 EndX: -0.57 in
 EndY: 0.51 in
 Area: 2.97 in²
 Max stitch: 7.0 mm
 Min stitch: 0.2 mm
 Max jump: 6.3 mm
 Total thread: 34.34ft
 Total bobbin: 13.62ft

Stop Sequence:

#	N#	Color	St.	Code	Name	Chart
1.	4		763	R126	G132 B138	
2.	2		301	R40	G48 B51	
3.	4		515	R126	G132 B138	

